



Surface roughness testing



TESA
TECHNOLOGY

Roughness Measurement

Roughness gauges are instruments used to determine surface irregularities, such as the level of wear on metal surfaces or the condition of surfaces after machining.

TESA roughness gauges are classic compact models using a highly resistant diamond tip. This tip will scan these irregularities so that the instrument can determine a profile. The determination of the tip to be measured is important since it will allow, according to the surface to be measured, to reach a more or less high precision.

Once the micro-geometric asperities of the surface are measured, parameter values are defined, thus qualifying the defects of the controlled zone.

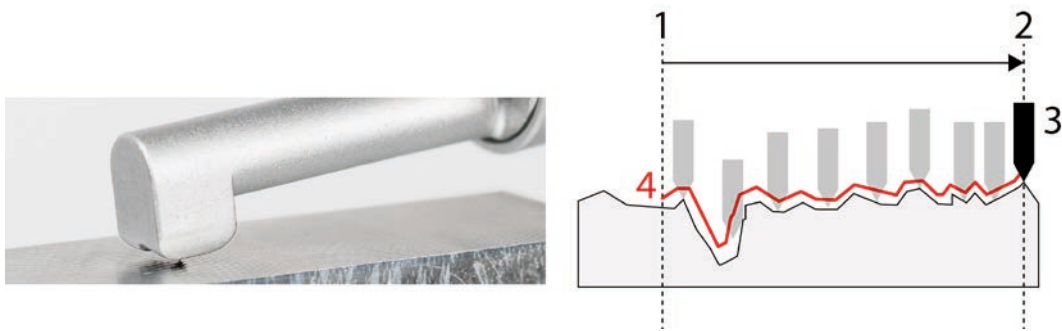

(1) Start of measurement, (2) End of measurement, (3) Diamond tip, (4) Measured profile

TESA Roughness Gauges

RUGOSURF 20

A portable and compact roughness tester, its large screen allows the user to directly display the measured profiles and available graphics.

TWIN-SURF

A portable and ultra-compact roughness tester, this instrument allows measurements in hard-to-reach places thanks to its feature that allows the probe to be positioned at 90°. It can also be mounted on other instruments such as height gauges. A model with integrated Bluetooth® is available, allowing data to be send directly to a wireless printer.

RUGOSURF 90G

Roughness tester that can also be transformed into a profile meter by using the PROFILE SET 2 mm option. It can also measure in three directions: +90°, 0 and -90°.



TWIN-SURF, RUGOSURF 20, RUGOSURF 90G

Surface roughness testing

RUGOSURF 20



TWIN-SURF

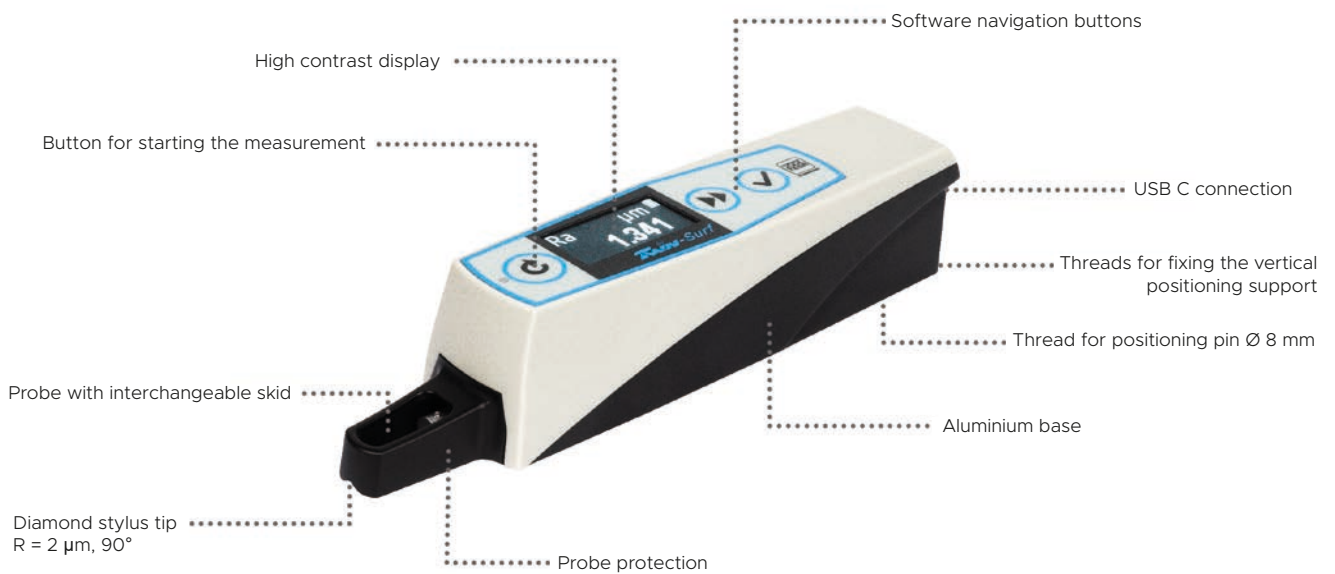

RUGOSURF 20

- INSTRUMENT
 - Portable and robust
 - 3 buttons on top of the product for easy instrument configuration
 - Interchangeable probes
- AUTONOMY
 - Can be operated with power supply or battery
- MEASUREMENT
 - Suitable for use in production environments or for incoming inspection
 - Access to narrow and deep areas thanks to the 100 mm probe extension (optional)
- FUNCTIONS (with DATA-STUDIO, basic version)
 - R-profile display
 - 13 roughness parameters available
 - 10 measurements usable for statistical processing
 - Storage of 10 measurement programs
 - Each parameter can be individually activated
 - Tolerancing possible for each parameter
- DATA MANAGEMENT
 - Transfer of measurements, creation of database, report with DATA-STUDIO software



06930013

Article number	Designation
06930013	RUGOSURF 20 roughness gauge

Accessories

Article number	Designation
04760099	USB to micro-USB cable
06960035	Support with granite table, 400 x 250 mm
06960081	SB10-2 probe, for RUGOSURF 20, R = 2 μm , 90°
06960036	SB10 probe, for RUGOSURF 20, R = 5 μm , 90°
06960037	SB20 probe, for RUGOSURF 20, for groove of depth < 5 mm
06960038	SB30 probe, for RUGOSURF 20, for bores $\varnothing > 4$ mm
06960039	SB40 probe, for RUGOSURF 20, V-shape for cylinders $\varnothing > 1$ mm
06960040	SB50 probe, for RUGOSURF 20, for concave surfaces or 90°
06960056	100 mm extension for probe with skid, for RUGOSURF 20
06960057	SB110 probe, for RUGOSURF 20, for concave or convex surfaces R > 5 mm
06960063	Battery NiMH 8,4V, 170 mAh, format PP3
06960046	Power supply 100 \div 240 V, 50 \div 60 Hz, 12 V, 400 \div 600 mAh
06960041	Roughness standard, Ra = 2,97 μm
06960064	Roughness standard, Ra = 0,1 μm
06960065	Roughness standard, Ra = 0,5 μm
06960066	Roughness standard, Ra = 1 μm
06960091	DATA-STUDIO software

Roughness gauges

Standard	ISO 3274, ISO 4287, ISO 12085
Measuring range	Z: $\pm 200 \mu\text{m}$ X: 16 mm
Range of indication	Ra = $0 \div 100 \mu\text{m}$ Rt = $0,05 \div 400 \mu\text{m}$
Max. perm. errors	R = roughness in μm $0,05 \mu\text{m} + (5\% R)$
Resolution	$0,001 \mu\text{m} / .01 \mu\text{in}$
Material	Stylus tip: diamond
Dimensions	Housing: 122 x 60 x 62 mm Screen: 160 x 100 pixels Tip: R2 μm , 90°
Degree of protection	Keyboard: IP67
Display	LCD, black/white
Weight	650 g
Data output(s)	Micro-USB
Measuring force	0,75 mN
Units	mm / in
Roughness parameters	Available with the RUGOSURF 20 used in conjunction with the following TESA DATA-STUDIO versions: Basic version: According to ISO 4287: Ra, Rq, Rt, Rz, Rc, Rmax, RSm, RPC According to ISO 12085: Pt, R, AR, Rx, PPc Premium version: According to ISO 12085: Rke, Rpke, Rvke, A1e, A2e, Mr1e, Mr2e According to ISO 4287: Rp, Rv, Rsk, Rku, RΔq, RΔa, Rmr rel, Rδc, Rmr(c) Pa, Pq, Pp, Pv, Pt, Pc, RPC, R3z Psk, Pku, PSm, PΔq, Pmr rel, Pδc, Pmr(c) Rk, Rpk, Rvk, A1, A2, Mr1, Mr2 as well as all parameters of the basic version
Graphic(s)	With DATA-STUDIO version: Basic: R-profile Premium: P-profile, Rk-profile Number: 1 - 5
Cut-off	Lengths: 0,25 - 0,8 - 2,5 mm (ISO 4287) 1,5 - 2,5 - 4 - 8 - 12 - 16 mm (ISO 12085)
Memory	Measurements with parameters: < 1'000 Measurements with profile and graph: < 20
Probe displacement speed	1 mm/s
Delay before measurement	4 to 10 s
Included in delivery	1x RUGOSURF 20 1x SB10-2 probe, R = 2 μm 1x standard, Ra = 2,97 μm 1x positioning pin \varnothing 8 mm 1x vertical positioning support 1x removable probe protection 1x rechargeable battery 1x charger and UE/US adapter

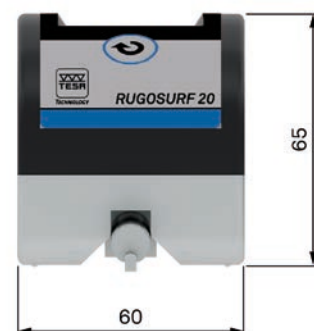
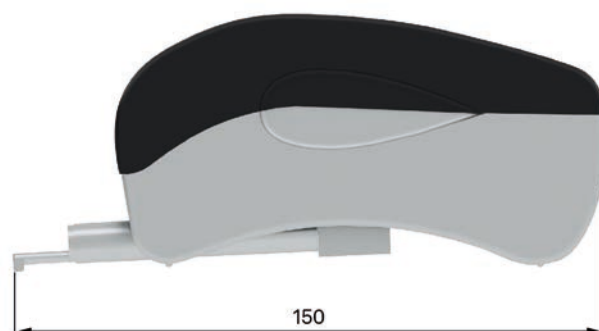

RUGOSURF 90G

- INSTRUMENT
 - Vertical adjustment screw for probe positioning (up to 90 mm) without accessories
 - Can be transformed into a profile measurer by using the PROFILE SET 2 mm option
- MEASURE
 - Suitable for use in production environments or for incoming inspection
 - 3 horizontal measuring positions of the probe: 0°, -90° and +90°.
 - Roughness or waviness measurement with one probe (probe with removable skid)
- FUNCTIONS
 - R-profile measurement
 - P-profile measurement
 - W-profile measurement
 - 51 roughness parameters available
 - Tolerancing possible for each parameter
- DATA MANAGEMENT
 - USB output for transferring measured values to a computer
 - TESA MEASUREMENT STUDIO software (optional)



06930012

Article number	Designation
06930012	RUGOSURF 90G roughness gauge

Accessories

Article number	Designation
06960062	USB cable, RUGOSOFT 90G to computer
06960048	MEASUREMENT STUDIO software
06960067	SB60/10-2 probe, for RUGOSURF 90G, detachable skid, R = 2 µm, 90°
06960050	SB20P probe, for RUGOSURF 90G, for groove of depth < 5 mm
06960051	SB30P probe, for RUGOSURF 90G, for bores Ø > 4 mm
06960052	SB40P probe, for RUGOSURF 90G, V-shape for cylinders Ø > 1 mm
06960053	SB50P probe, for RUGOSURF 90G, for concave surfaces or 90° measurement
06960054	SB120P probe, for RUGOSURF 90G, for groove of depth < 20 mm
06960058	SB120S probe, for RUGOSURF 90G, for groove of depth < 15 mm
06960061	SB60-D2 probe, for RUGOSURF 90G, for bores Ø > 2 mm
06960049	SB60/10 probe, for RUGOSURF 90G, detachable skid, R = 5 µm, 90°
06960041	Roughness standard, Ra = 2,97 µm
06960064	Roughness standard, Ra = 0,1 µm
06960065	Roughness standard, Ra = 0,5 µm
06960066	Roughness standard, Ra = 1 µm
06960100	PROFILE SET, 2 mm
06960055	Support with granite table, 630 x 400 mm

Roughness gauges

Standard	ISO 3274, ISO 4287, ISO 12085
Measuring range	Z: $\pm 500 \mu\text{m}$ X: 50 mm
Range of indication	Ra = 0 ÷ 400 μm Rt = 0 ÷ 1000 μm
Max. perm. errors	R = roughness in μm 0,05 μm + (5% R)
Resolution	0,001 μm / .01 μin
Material	Stylus tip: diamond
Dimensions	Housing: 270 x 140 x 90 mm Screen: 320 x 240 pixels Tip: R2 μm , 90°
Degree of protection	Keyboard: IP67
Display	TFT, color
Weight	3 kg
Data output(s)	Micro-USB
Measuring force	0,75 mN
Units	mm / in
Roughness parameters	According to ISO 4287: Ra, Rq, Rt, Rp, Rc, Rv, RSm, R δ c, RPc Pa, Pq, Pp, Pc, Pv, PSm, P δ c Wa, Wq, Wt, Wp, Wc, Wv, WSm, W δ c, WPC Rmr, Rz, Rmax, Rsk, Rku, Wz Rk, Rpk, Rvk, Mr1, Mr2 As per DB N 31007: R3z, R3zm According to ISO 12085: Pt, R, Rx, AR, Wte, W, AW, Wx, Rke, Rpke, Rvke, Pdc, Ppc, Mr1e, Mr2e
Graphic(s)	Bearing area curve P-profile R-profile W-profile
Cut-off	Length: 0,08 - 0,25 - 0,80 - 2,50 - 8,00 mm Number: 1 - 19 for cut-off up to 2,5 mm 1 - 5 for cut-off 8,0 m
Memory	Measurements with parameters: < 60'000
Probe displacement speed	0,5 or 1 mm/s
Included in delivery	1x RUGOSURF 90G 1x SB60/10-2 probe with skid 1x standard, Ra = 2,97 μm 1x probe holder 1x guide column, vertical stroke of 90 mm 1x rechargeable battery 1x charger and UE/US adapter

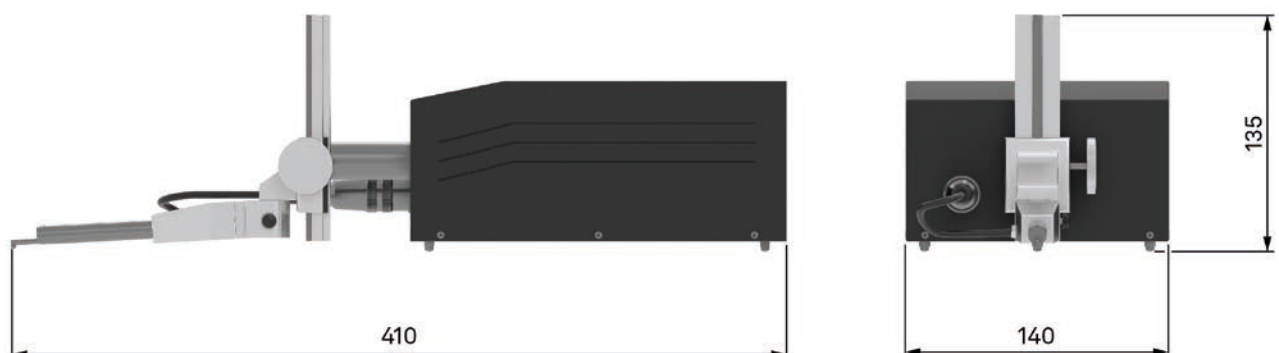

TWIN-SURF

- INSTRUMENT
 - Ultra-compact, portable and robust
 - High contrast display for comfortable reading in dark environments
 - 3 buttons on top of the product for easy instrument configuration
 - Interchangeable probes
- AUTONOMY
 - Can be operated with power supply or battery
- MEASUREMENT
 - Suitable for use in production environments or for incoming inspection
 - Access to narrow and deep areas thanks to the 100 mm probe extension (optional)
 - 90° probe orientation for cross-sectional measurements
- FUNCTIONS (with DATA-STUDIO, basic version)
 - R-profile display
 - 13 roughness parameters available
 - 10 measurements usable for statistical processing
 - Storage of 10 measurement programs
 - Each parameter can be individually activated
 - Tolerancing possible for each parameter
- DATA MANAGEMENT
 - Standard version connectable to a computer via cable
 - Bluetooth® version wirelessly connectable to a computer, tablet or smartphone
 - Free TESA DATA-STUDIO software (basic version) included for creating measurement reports, statistical management, measurement parameters.



06930014

Article number	Designation
06930014	TWIN-SURF roughness gauge
06930015	TWIN-SURF roughness gauge, Bluetooth® version

Accessories

Article number	Designation
06960092	SB21 probe, for TWIN-SURF, for groove of depth < 5 mm
06960093	SB31 probe, for TWIN-SURF, for bores $\varnothing > 4$ mm, depth < 20 mm
06960094	SB51 probe, for TWIN-SURF, for concave surfaces or 90° measurement, for groove of depth < 5 mm
06960095	SB121 probe, for TWIN-SURF, for groove of depth < 20 mm
06960096	Extension for TWIN-SURF, 100 mm
04760152	USB A to USB C cable, 1 m
06960090	Bluetooth® printer
06960091	DATA-STUDIO software

Roughness gauges

Standard	ISO 3274, ISO 4287, ISO 12085
Measuring range	Z: $\pm 200 \mu\text{m}$ X: 17,5 mm
Range of indication	Ra = $0 \div 50 \mu\text{m}$ Rt = $0,05 \div 200 \mu\text{m}$
Max. perm. errors	R = roughness in μm $0,05 \mu\text{m} + (5\% R)$
Resolution	$0,001 \mu\text{m} / .01 \mu\text{in}$
Material	Stylus tip: diamond
Dimensions	Housing: 160 x 34 x 34 mm Screen: 128 x 64 pixels Tip: R2 μm , 90°
Degree of protection	Keyboard: IP67
Display	OLED, monochrome
Weight	200 g
Data output(s)	USB C
Measuring force	0,75 mN
Units	mm / in
Roughness parameters	Available with the TWIN-SURF used in conjunction with the following TESA DATA-STUDIO versions: Basic version: According to ISO 4287: Ra, Rq, Rt, Rz, Rc, Rmax, RSm, RPC According to ISO 12085: Pt, R, AR, Rx, PPc Premium version: According to ISO 12085: Rke, Rpke, Rvke, A1e, A2e, Mr1e, Mr2e According to ISO 4287: Rp, Rv, Rsk, Rku, RΔq, RΔa, Rmr rel, Rδc, Rmr(c) Pa, Pq, Pp, Pv, Pt, Pc, RPC, R3z Psk, Pku, PSm, PΔq, Pmr rel, Pδc, Pmr(c) Rk, Rpk, Rvk, A1, A2, Mr1, Mr2 and all the parameters of the basic version
Graphic(s)	With DATA-STUDIO version: Basic: R-profile Premium: P-profile, Rk-profile Number: 1 - 5
Cut-off	Lengths: 0,25 - 0,8 - 2,5 mm (ISO 4287) 1,5 - 2,5 - 4 - 8 - 12 - 16 mm (ISO 12085)
Memory	Measurements with parameters: < 18'000 (evaluation length: 0,8 x 5 mm) Measurements with profile and graph: < 30
Probe displacement speed	0,5 or 1 mm/s
Delay before measurement	0 to 10 s
Included in delivery	1x TWIN-SURF 1x probe SB51 1x standard, Ra = 2,97 μm 1x positioning pin \varnothing 8 mm 1x key for protection management 1x charger and EU/US adapter 1x USB A-C cable DATA-STUDIO software (basic version) Measuring report Declaration of conformity

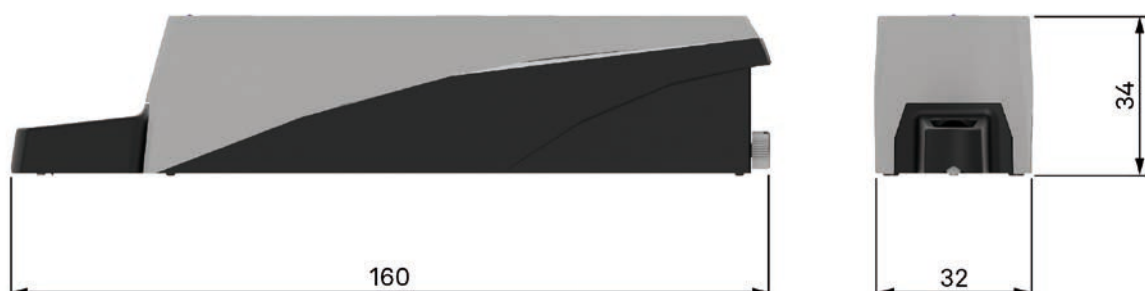

PROFILE SET 2 mm

- USE
 - Transforms the RUGOSURF 90G into a profile measuring device
 - For the measurement of lengths, radii and angles
- FUNCTIONS (with PROFILE STUDIO software)
 - Dimensions can be inserted on the measured profile after defining the geometrical elements (point, line, arc or intersection between 2 lines 'for example')
 - A previous measurement can be used as a measurement template for repeating a measurement of a part with identical geometry
 - A detailed measurement report with customizable header
 - Measurement command and help for calibration from computer
 - Import and export of measurement parameters from and to the instrument
 - Archiving of measurement results and measured parameters as a database



Measuring range	Z: 2 mm X: 50 mm
Max. perm. errors	Z: $3.5 + 0.75 \times H$ μm (H in Z axis, in mm) X: $3.5 + L/10$ μm (L in X axis, in mm)
Resolution	Z: 0,1 μm X: 0,4 to 4 μm (depending on measured length)
Measuring force	0,003 mN with SB2000 probe
Roughness parameters	According to ISO 4287, ISO 13565-1, ISO 13565-2, ISO 12085, VDA 2007
Probe displacement speed	1 mm/s
Profile angles	Upward measurement: 70° Downward measurement: 85°

Article number	Designation
06960100	PROFILE SET, 2 mm

Accessories

Article number	Designation
06960101	PROFILE STUDIO software
06960102	SB2000 probe for PROFILE SET 2 mm, R = 15 μm , 20°
06960103	Setting master for PROFILE SET 2 mm
06960062	USB cable, RUGOSOFT 90G to computer

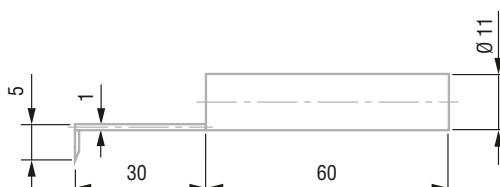

Accessories for roughness gauges

Probes and extension for RUGOSURF 20



Article number	Designation
06960036	SB10 probe, for RUGOSURF 20, R = 5 μm, 90°
06960037	SB20 probe, for RUGOSURF 20, for groove of depth < 5 mm
06960038	SB30 probe, for RUGOSURF 20, for bores Ø > 4 mm
06960039	SB40 probe, for RUGOSURF 20, V-shape for cylinders Ø > 1 mm
06960040	SB50 probe, for RUGOSURF 20, for concave surfaces or 90°
06960057	SB110 probe, for RUGOSURF 20, for concave or convex surfaces R > 5 mm
06960081	SB10-2 probe, for RUGOSURF 20, R = 2 μm, 90°
06960056	100 mm extension for probe with skid, for RUGOSURF 20

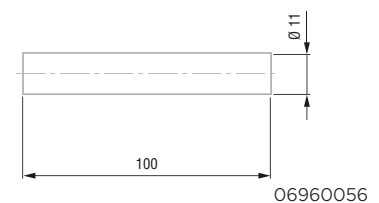
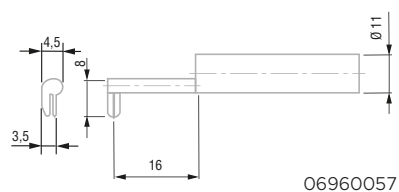
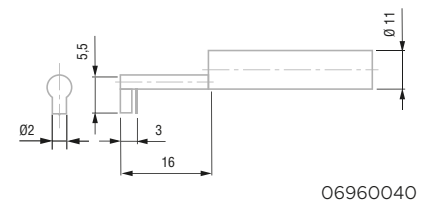
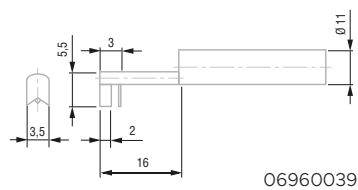
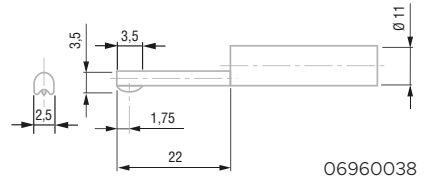
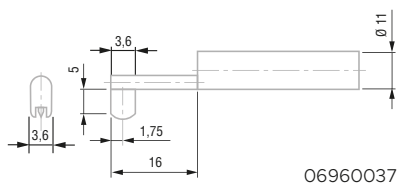
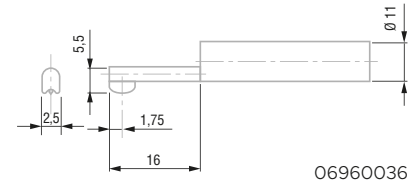
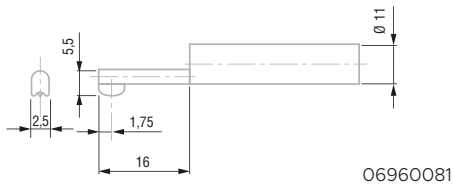

Probes and extension for TWIN-SURF

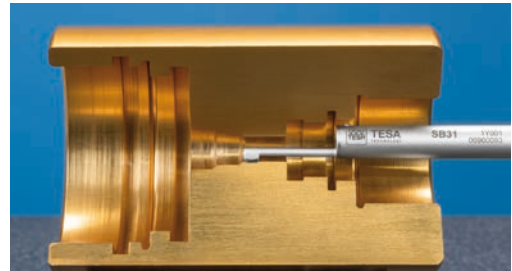

Article number	Designation
06960092	SB21 probe, for TWIN-SURF, for groove of depth < 5 mm
06960093	SB31 probe, for TWIN-SURF, for bores $\varnothing > 4$ mm, depth < 20 mm
06960094	SB51 probe, for TWIN-SURF, for concave surfaces or 90° measurement, for groove of depth < 5 mm
06960095	SB121 probe, for TWIN-SURF, for groove of depth < 20 mm
06960096	Extension for TWIN-SURF, 100 mm

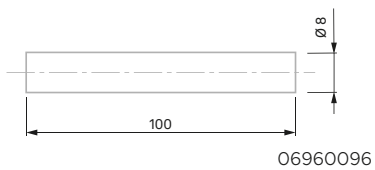
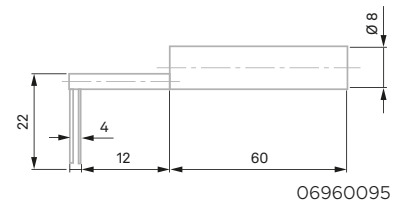
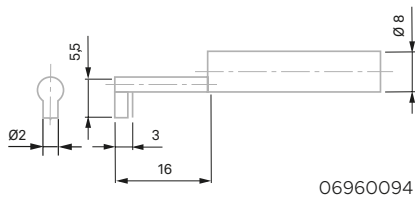
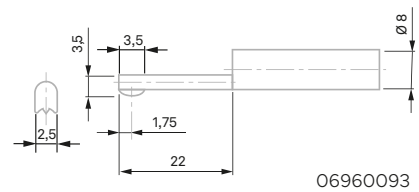
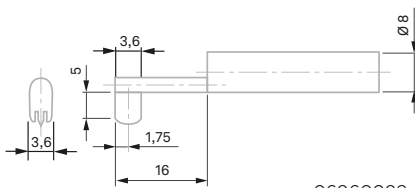

Accessories for roughness gauges

Probes and extension for RUGOSURF 90G



Article number	Designation
06960049	SB60/10 probe, for RUGOSURF 90G, detachable skid, R = 5 μ m, 90°
06960050	SB20P probe, for RUGOSURF 90G, for groove of depth < 5 mm
06960051	SB30P probe, for RUGOSURF 90G, for bores \varnothing > 4 mm
06960052	SB40P probe, for RUGOSURF 90G, V-shape for cylinders \varnothing > 1 mm
06960053	SB50P probe, for RUGOSURF 90G, for concave surfaces or 90° measurement
06960054	SB120P probe, for RUGOSURF 90G, for groove of depth < 20 mm
06960058	SB120S probe, for RUGOSURF 90G, for groove of depth < 15 mm
06960061	SB60-D2 probe, for RUGOSURF 90G, for bores \varnothing > 2 mm
06960067	SB60/10-2 probe, for RUGOSURF 90G, detachable skid, R = 2 μ m, 90°
06960056	100 mm extension for probe with skid, for RUGOSURF 90G

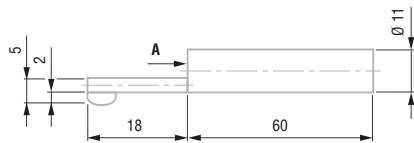

06960067

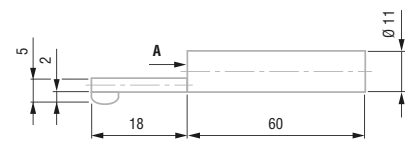

06960049

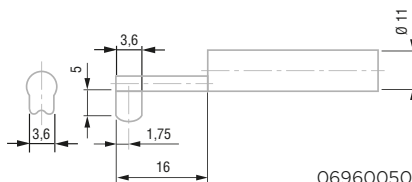

06960050

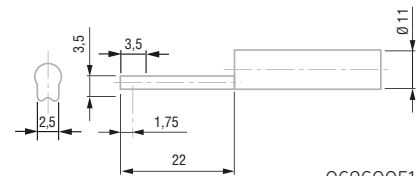

06960051

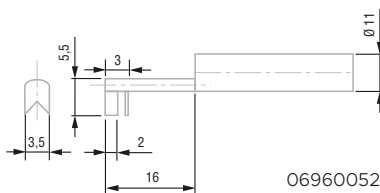

06960052

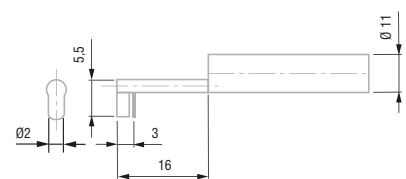

06960053

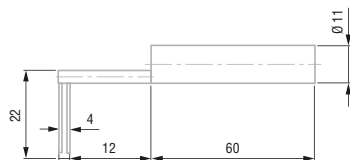

06960054

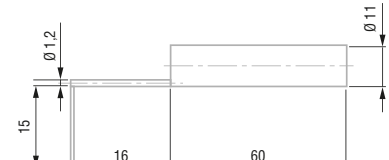

06960058

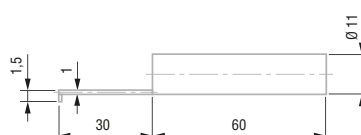

06960061

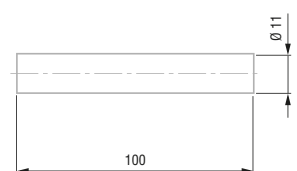

06960056

Support group



06960055

Article number	Designation
06960055	Support with granite table, 630 x 400 mm

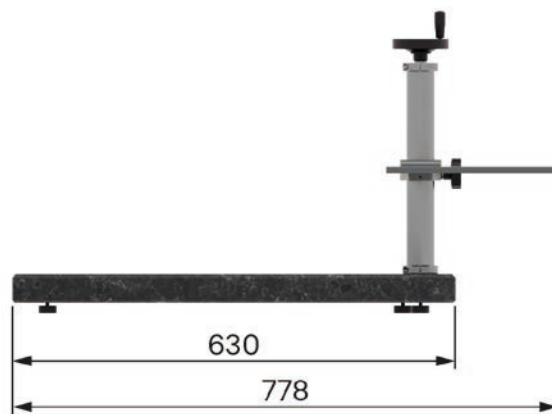
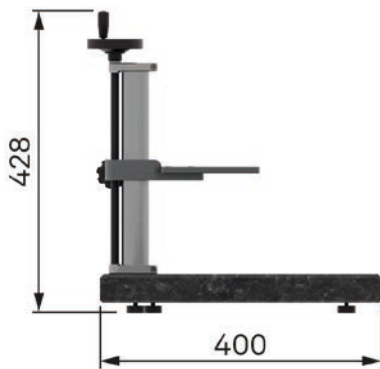

Calibration standards

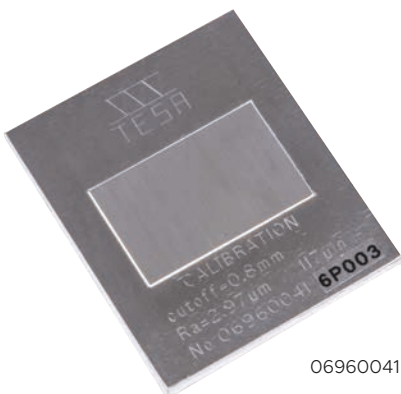

06960041

Article number	Designation
06960041	Roughness standard, Ra = 2,97 µm
06960066	Roughness standard, Ra = 1 µm
06960065	Roughness standard, Ra = 0,5 µm
06960064	Roughness standard, Ra = 0,1 µm

Software for roughness gauges

MEASUREMENT STUDIO

- COMPATIBILITY
 - For RUGOSURF 90G
- FUNCTIONS
 - Remote management of measurement start-up and calibration
 - Visualization of the measured parameters
 - Visualization of roughness profiles R, primary P and waviness W
 - Calculation of roughness parameters, including VDA parameters
 - Calculation of statistics from a set of measurements
 - Adjustable upper and lower tolerance for each parameter
 - Creation and storage of measurement programs (instrument settings and parameters to be measured)
 - Transferable measurement programs on the instrument
 - Measurement report with customizable header
 - 51 parameters available
- DATA MANAGEMENT
 - Connection to the instrument via USB
 - Import of saved measurements from the instrument to the computer, for the management of a database
 - Measurement report in .xls, .pdf, .doc, .rpt or .rtf format

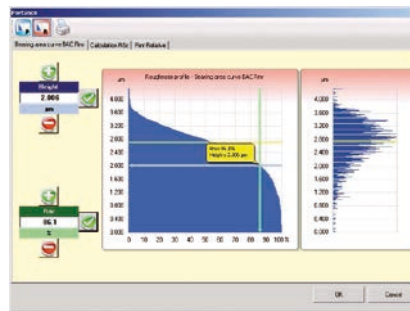

Par VDA 2007			
Parameter	Value	Tol-	Tol+
WDSm	0.273 μm		
WDc	0.971 μm		
WDt	2.243 μm		

Included in delivery

License key (dongle)
 USB-PC connection cable, 1,80 m
 User manual
 Software installation file

Article number

Designation

06960048 MEASUREMENT STUDIO software

DATA-STUDIO

- COMPATIBILITY
 - For RUGOSURF 20
 - For TWIN-SURF
- FUNCTIONS
 - Remote management of measurement start and calibration
 - Visualization of the measured parameters
 - Visualization of the measured roughness profiles R, primary P and Rk
 - Calculation of roughness parameters, including VDA parameters
 - Statistical calculations from several measurements
 - Adjustable upper and lower tolerance for each parameter
 - Creation and archiving of measurement programs (instrument settings and parameters to be measured)
 - Measurement programs transferable to the instrument
 - Measurement report for each parameter head
 - 51 parameters available with the Premium version
- DATA MANAGEMENT
 - Connection to the instrument via USB or Bluetooth (depending on the instrument)
 - Import of measurements saved from the instrument to the computer for data base management
 - Printing of results with printer accessory
 - Measurement report in .xls and .pdf format

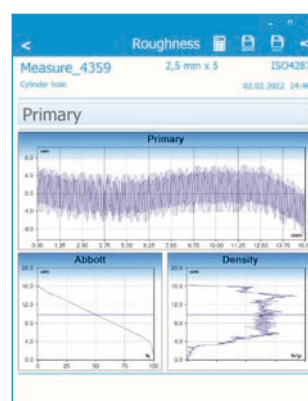
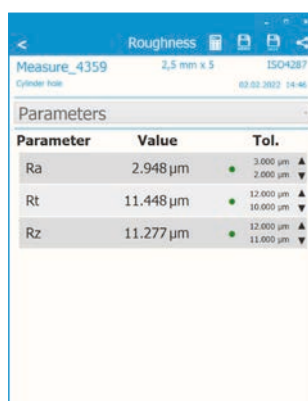

Included in delivery

1x USB key including:
User manual
Software installation file

Article number

Designation

06960091

DATA-STUDIO software